

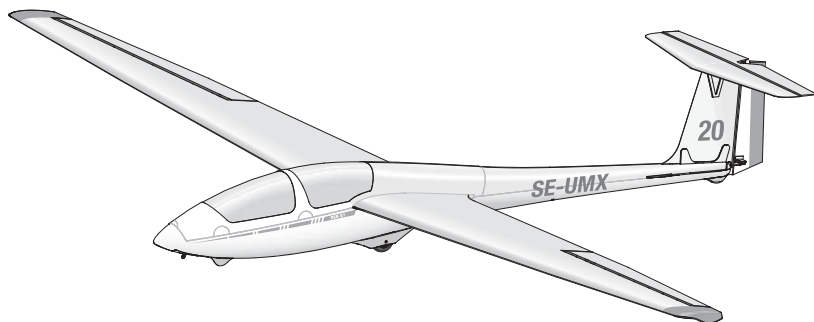

Bind-N-Fly.™ Ready to fly, redefined.

UMX™ ASK-21



***Instruction Manual
Bedienungsanleitung
Manuel d'utilisation
Manuale di Istruzioni***

AS3X®

E-flite®
ADVANCING ELECTRIC FLIGHT

NOTICE

All instructions, warranties and other collateral documents are subject to change at the sole discretion of Horizon Hobby, Inc. For up-to-date product literature, visit www.horizonhobby.com and click on the support tab for this product.

Meaning of Special Language:

The following terms are used throughout the product literature to indicate various levels of potential harm when operating this product:

NOTICE: Procedures, which if not properly followed, create a possibility of physical property damage AND little or no possibility of injury.

CAUTION: Procedures, which if not properly followed, create the probability of physical property damage AND a possibility of serious injury.

WARNING: Procedures, which if not properly followed, create the probability of property damage, collateral damage, and serious injury OR create a high probability of superficial injury.

 **WARNING:** Read the ENTIRE instruction manual to become familiar with the features of the product before operating. Failure to operate the product correctly can result in damage to the product, personal property and cause serious injury.

This is a sophisticated hobby product. It must be operated with caution and common sense and requires some basic mechanical ability. Failure to operate this product in a safe and responsible manner could result in injury or damage to the product or other property. This product is not intended for use by children without direct adult supervision. Do not attempt disassembly, use with incompatible components or augment product in any way without the approval of Horizon Hobby, Inc. This manual contains instructions for safety, operation and maintenance. It is essential to read and follow all the instructions and warnings in the manual, prior to assembly, setup or use, in order to operate correctly and avoid damage or serious injury.

Age Recommendation: Not for children under 14 years. This is not a toy.

Thank you for purchasing the E-flite® UMX™ ASK-21 scale RC sailplane. A first of its kind in its size class is a fully functional 4-channel aircraft capable of loops and rolls, as well as traditional thermal and slope soaring. Lightweight and sleek, your new UMX ASK-21 is equipped with AS3X® System technology specially tuned for the many variations of flight conditions you'll encounter, so that you get the smooth experience similar to that of flying a giant-scale sailplane. And like the giant-scale sailplanes, this UMX ASK-21 is tow hook equipped making it aerotow capable when paired with the powerful E-flite UMX Carbon Cub SS (EFLU1180). Another strong benefit of the AS3X® is its outstanding ability to stabilize the glider while on a tow line or Hi-start and help prevent common issues, such as heading loss, which can make smooth flight difficult. Please be sure to read through this manual carefully so that you can successfully enjoy all the benefits this outstanding ultra-micro model has to offer.

Table of Contents

Preflight Checklist.....	4	Towing.....	12
Charging Warnings.....	4	Tips for Towing.....	13
Charging the Battery.....	5	Tow Release Installation.....	13
Wing Installation.....	6	Flying Tips and Repairs.....	14
Transmitter and Receiver Binding.....	7	Additional Safety Precautions and Warnings.....	15
Installing the Flight Battery.....	7	Troubleshooting Guide.....	15
Initializing AS3X.....	8	Troubleshooting Guide (Continued).....	16
Control Centering.....	8	Limited Warranty.....	17
Settings for Control Horns.....	8	Warranty and Service Information.....	18
Control Direction Test.....	9	Compliance Information for the European Union..	18
Dual Rates.....	9	Replacement Parts.....	70
Adjusting Center of Gravity (CG).....	9	Optional Parts and Accessories.....	71
Hi-Start Hook Installation.....	10	Parts Contact Information.....	71
Hi-Start Launch.....	10		

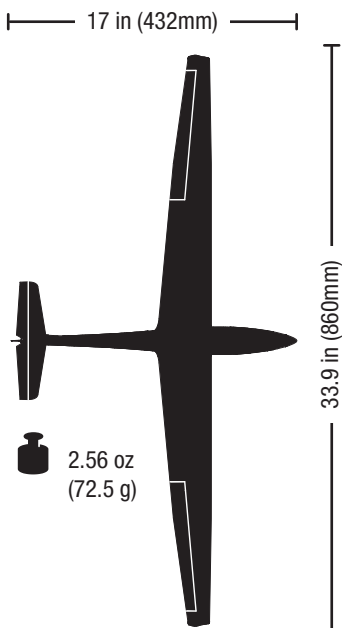

Installed



Receiver: DSM2/DSMX 6Ch UM AS3X Receiver ESC (EFLU1264)



Servos: (1) 2.3-Gram Performance Linear Long Throw Servo (SPMSA2030L)
(2) 2.3-Gram Linear Long Throw Offset Servo (SPMSA2030LO)
(2) (SPMSA2030L) on the board

Included



Battery: 150mAh 1S 25C Li-Po (EFLB1501S25)



Battery Charger: 1S 3.7V Li-Po (EFLC1000)

Additional Components:

4 AA Batteries
Tow Line (EFLU1257)
Tow Plate (EFLU1255)
Hi-Start and Stake (EFLU1258)
Hi-Start Hook and Screw (EFLU1255)

Needed to Complete



Recommended Transmitter: Spektrum™ Full range DSM2®/DSMX® with dual-rates (DX4e and up)

Preflight Checklist

✓	
	1. Charge flight battery.
	2. Install flight battery in aircraft (once it has been fully charged).
	3. Bind aircraft to transmitter.
	4. Make sure linkages move freely.
	5. Perform Control Direction Test with transmitter.

✓	
	6. Set dual rates.
	7. Adjust center of gravity.
	8. Perform a radio system Range Check.
	9. Find a safe and open area.
	10. Plan flight for flying field conditions.

AS3X Stabilization Delivers Breakthrough Performance

Horizon Hobby has always made RC sport, scale and unique aircraft with the kind of performance experts appreciate. Now the exclusive Artificial Stability – 3 aXis (AS3X) system helps take performance expectations in ultra micro aircraft a quantum leap higher.

Based on the successful use of MEMS sensor technology within the AS3X Stabilization System essential to Blade® ultra micro flybarless

helicopters, the specifically tuned AS3X System for airplanes helps invisibly correct for turbulence, torque and tip stalls when encountered.

Furthermore, the outstanding control agility delivers an ultra smooth, locked-in feel that obeys your every command with performance that's natural feeling. It's so gratifying, in fact, that it's as though you're the RC pilot of an expertly tuned, giant-scale model.

AS3X will change the way you'll want to fly now and in the future. To see what we mean, go to www.E-fliteRC.com/AS3X.

Charging Warnings

The included battery charger (EFLC1000) has been designed to safely charge the Li-Po battery.

 **CAUTION:** All instructions and warnings must be followed exactly. Mishandling of Li-Po batteries can result in a fire, personal injury, and/or property damage.

- By handling, charging or using the included Li-Po battery, you assume all risks associated with lithium batteries.
- If at any time the battery begins to balloon or swell, discontinue use immediately. If charging or discharging, discontinue and disconnect. Continuing to use, charge or discharge a battery that is ballooning or swelling can result in fire.
- Always store the battery at room temperature in a dry area for best results.
- Always transport or temporarily store the battery in a temperature range of 40–120° F (5–48° C). Do not store battery or aircraft in a car or direct sunlight. If stored in a hot car, the battery can be damaged or even catch fire.
- Always charge batteries away from flammable materials.
- Always inspect the battery before charging and never charge dead or damaged batteries.
- Always disconnect the battery after charging, and let the charger cool between charges.
- Always constantly monitor the temperature of the battery pack while charging.
- **ONLY USE A CHARGER SPECIFICALLY DESIGNED TO CHARGE LI-PO BATTERIES.** Failure to charge the battery with a compatible charger may cause fire resulting in personal injury and/or property damage
- Never discharge Li-Po cells to below 3V under load.
- Never cover warning labels with hook and loop strips.
- Never leave charging batteries unattended.
- Never charge batteries outside recommended levels.
- Never attempt to dismantle or alter the charger.
- Never allow minors to charge battery packs.
- Never charge batteries in extremely hot or cold places (recommended between 40–120° F or 5–48° C) or place in direct sunlight.

Charging the Battery

Your UMX ASK-21 comes with a 1S 3.7V Li-Po Battery Charger and a 1S Li-Po battery. You should only charge your 1S Li-Po battery with a Li-Po charger, such as the included charger or the E-flite® Celectra™ 4-port charger (EFLC1004).

Refer to the battery warnings. It is recommended to charge the battery pack while you are inspecting the aircraft. The flight battery will be required to confirm proper aircraft operation in future steps.

Please visit www.horizonhobby.com for optional battery adapters.

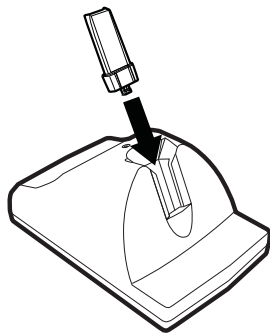

The Battery Charging Process

1. Charge only batteries that are cool to the touch and are not damaged. Look at the battery to make sure it is not damaged e.g., swollen, bent, broken or punctured.
2. Remove the cover on the bottom of the charger and install four of the included AA batteries, noting proper polarity. Replace the cover after the AA batteries are installed.
3. Slide the battery into the slot on the charger. The end cap of the battery is specifically designed to allow the battery to fit into the slot one way (usually with the label on the battery facing outward) to prevent reverse polarity connection. However, check for proper alignment and polarity before proceeding to the next step.
4. Gently press the battery and its connector into the charge jack/connector located at the bottom of the slot in the charger.
5. When you make the connection successfully, the LED on the charger turns solid red, indicating charging has begun.
6. Charging a fully discharged (not over-discharged) 150mAh battery takes approximately 30–40 minutes. As the battery nears full charge, the LED begins to blink.
7. When the battery is fully charged, the LED blinks approximately every 20 seconds or goes out entirely. If the LED stays on when the battery is removed, the AA batteries in the charger are low.
8. Always unplug the battery from the charger immediately upon completion of charging.

⚠ CAUTION: Overcharging a battery can cause a fire.

⚠ CAUTION: Only use a charger specifically designed to charge a Li-Po battery. Failure to do so could result in fire causing injury or property damage.

⚠ CAUTION: Never exceed the recommended charge rate.

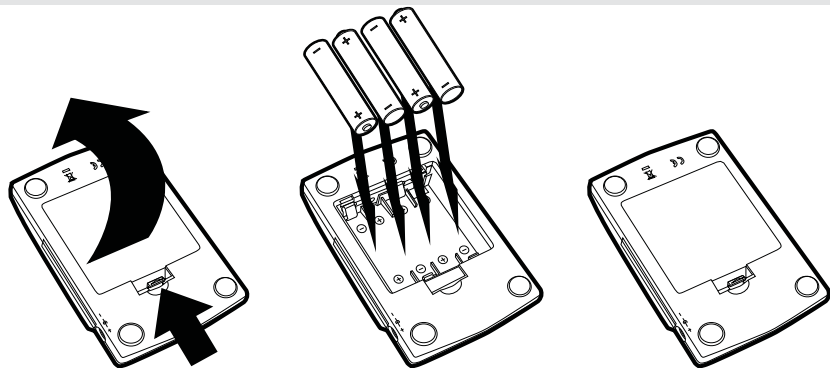

⚠ CAUTION: Only use an E-flite 6V power supply (EFLC1005) with this charger. DO NOT use a 12V power supply or property damage and injury could occur.

Wing Installation

1. Lift the front of the canopy (A) and pull it forward off the fuselage.
2. Align the 4 holes in the wing (B) with the 4 screw posts in the fuselage.
3. Secure the wing to the fuselage by fully tightening the 4 included screws (C).
4. Connect the aileron leads to the aileron ports on the receiver. Left aileron servo needs to be connected to the front port (D), right aileron servo needs connected to the rear port (E). The servos leads are labeled "L" and "R" for your convenience.
5. Be sure to check proper control directions before your first flight. You should not need to reverse any control surfaces.
6. Reinstall the canopy on the fuselage.

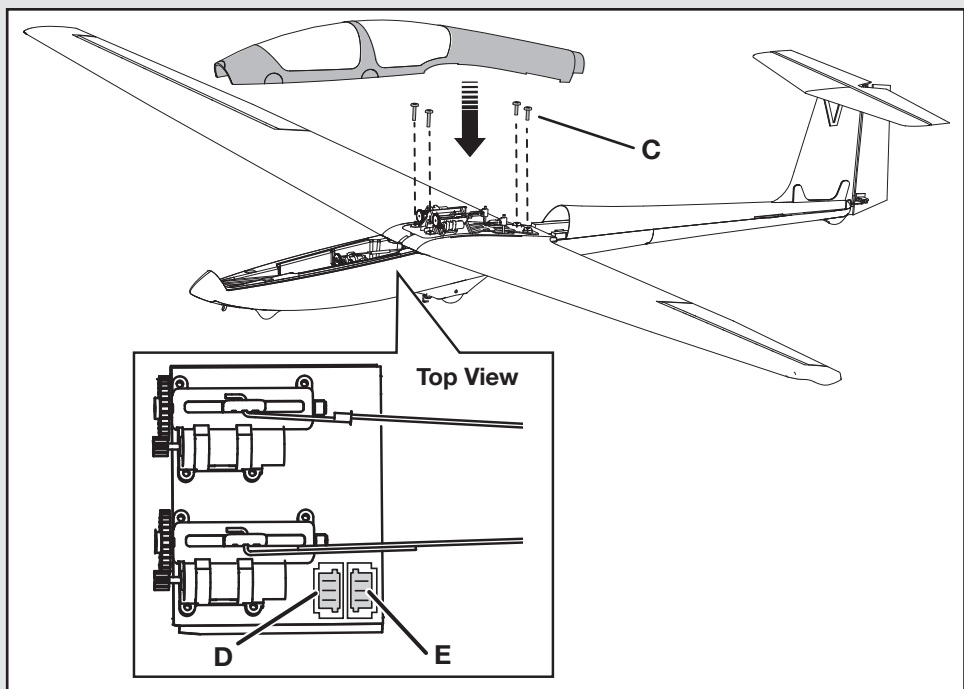
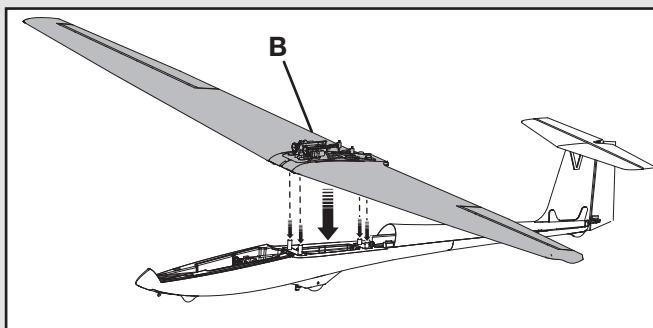
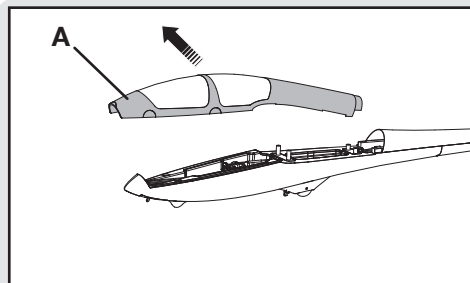

Transmitter and Receiver Binding

Binding is the process of programming the receiver of the control unit to recognize the GUID (Globally Unique Identifier) code of a single specific transmitter. You need to 'bind' your chosen Spektrum DSM2/DSMX technology equipped aircraft transmitter to the receiver for proper operation.

Any JR® or Spektrum DSM2/DSMX transmitter can bind to the AS3X DSM® receiver. For best flight performance of the UMX ASK-21, it is recommended that you use a transmitter with dual rates. Please visit www.bindnfly.com for a complete list of compatible transmitters.

NOTICE: When using a Futaba® transmitter with a Spektrum DSM module, reversing the throttle channel is required.

✓ Binding Procedure

1.	Refer to your transmitter's unique instructions for binding to a receiver.
2.	Make sure the flight battery is disconnected from the aircraft.
3.	Power off the transmitter.
4.	Connect the flight battery in the aircraft. The receiver LED will begin to flash rapidly (typically after 5 seconds).
5.	Make sure the transmitter controls are at neutral and the throttle and throttle trim are in the low position.
6.	Put your transmitter into bind mode. Refer to your transmitter's manual for binding button or switch instructions.
7.	After 5 to 10 seconds, the receiver status LED will become solid, indicating that the receiver is bound to the transmitter. If the LED does not turn solid, refer to the Troubleshooting Guide at the back of the manual.

For subsequent flights, power on the transmitter for 5 seconds before connecting the flight battery.

Installing the Flight Battery

1. Lift the front of the canopy and pull the canopy forward off the fuselage.
2. Install the flight battery onto the hook and loop strip (A) in the battery compartment as far forward as possible.
3. Refer to Initializing AS3X instructions for connecting the battery to the receiver.
4. Install the canopy on the fuselage

Do not operate the ASK-21 for longer than 25 minutes on fully charged battery.

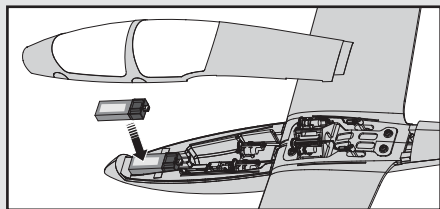
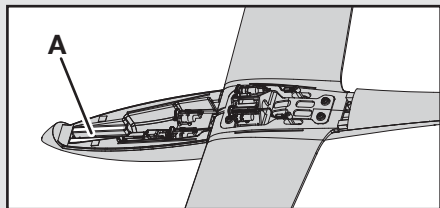
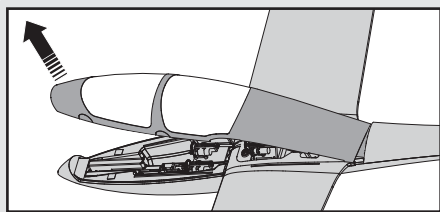

NOTICE: Always ensure that the battery is secured in the aircraft using hook and loop tape.

⚠ CAUTION: Always disconnect the Li-Po battery from the aircraft receiver when not flying to avoid over-discharging the battery. Batteries discharged to a voltage lower than the lowest approved voltage may become damaged, resulting in loss of performance and potential fire when batteries are charged.

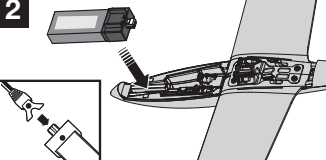
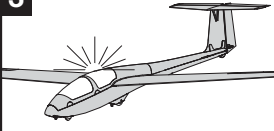

Initializing AS3X

Initializing AS3X also occurs after binding as previously described, but subsequent connection of a flight battery requires the steps below.

<p>1</p> 	<p>2</p> 	<p>3</p> 
<p>Power on the Transmitter, then wait 5 seconds</p>	<p>Install the flight battery and connect it to the receiver.</p>	<p>Keep the plane immobile and away from wind for 5 seconds.</p> <p> Continuous LED</p>

The AS3X system will not activate until the throttle stick or trim is increased for the first time. Once AS3X is active, the control surfaces may move rapidly on the aircraft. This is normal.

AS3X will remain active until the battery is disconnected.

Control Centering

Before the first flights, or in the event of an accident, make sure the flight control surfaces are centered. Adjust the linkages mechanically if the control surfaces are not centered. Use of the transmitter sub-trims may not correctly center the aircraft control surfaces due to the mechanical limits of linear servos.

1. Make sure the control surfaces are neutral when the transmitter controls and trims are centered. The transmitter sub-trim must always be set to zero.
2. When needed, use a pair of pliers to carefully bend the metal linkage (see illustration).
3. Make the U-shape narrower to make the connector shorter. Make the U-shape wider to make the linkage longer.

Centering Controls After First Flights

For best performance with AS3X, it is important that excessive trim is not used. If the model requires excessive transmitter trim (4 or more clicks of trim per channel), return the transmitter trim to zero and adjust the linkages mechanically so that the control surfaces are in the flight trimmed position.

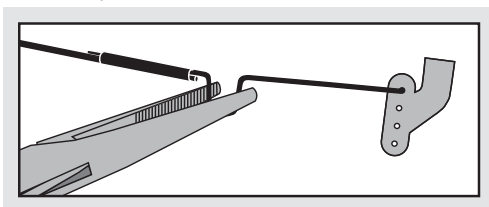

Settings for Control Horns

Only the factory setting for the rudder control horn is shown here because only the rudder linkage can be adjusted. After flying, carefully adjust the linkage position for the desired control response.

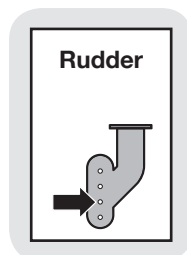

Control Direction Test

You should bind your aircraft and transmitter before doing these tests. Move the controls on the transmitter to make sure aircraft control surfaces move correctly and in the proper direction.

Make sure tail linkages move freely and that paint or decals are not adhered to them.

Dual Rates

To obtain the best flight performance, we recommend using a DSM2/DSMX radio capable of Dual Rates. The suggested settings shown here are the recommended starting settings. Adjust according to the individual preferences after the initial flight.

NOTICE: Do not set your transmitter travel adjust over 100%. If the TRAVEL ADJUST is set over 100%, it will not result in more control movement, it will overdrive the servo and cause damage.

It is normal for linear servos to make significant noise. The noise is not an indication of a faulty servo.

Dual Rates		High Rate	Low Rate
	Aileron	100%	70%
	Elevator	100%	70%
	Rudder	100%	70%

Tip: For the first flight, fly the model in low rate.

Tip: For landing, we recommend using high rate elevator.

Adjusting Center of Gravity (CG)

The CG location is **18mm** back from leading edge of the wing at the root. This CG location has been determined with the included 1S 150mAh 3.7V Li-Po battery installed in the front of the battery tray.

Test Glide Your Aircraft

Before your first flight, we recommend you test glide your aircraft to adjust trim, if needed. Hand launch your aircraft into the wind in calm conditions and let it glide to land in soft grass. Adjust the control linkages (see control centering) if your aircraft does not glide straight and level to the ground. Perform this process as many times as needed to trim the aircraft to respond as you desire before your first tow or Hi-Start launch.

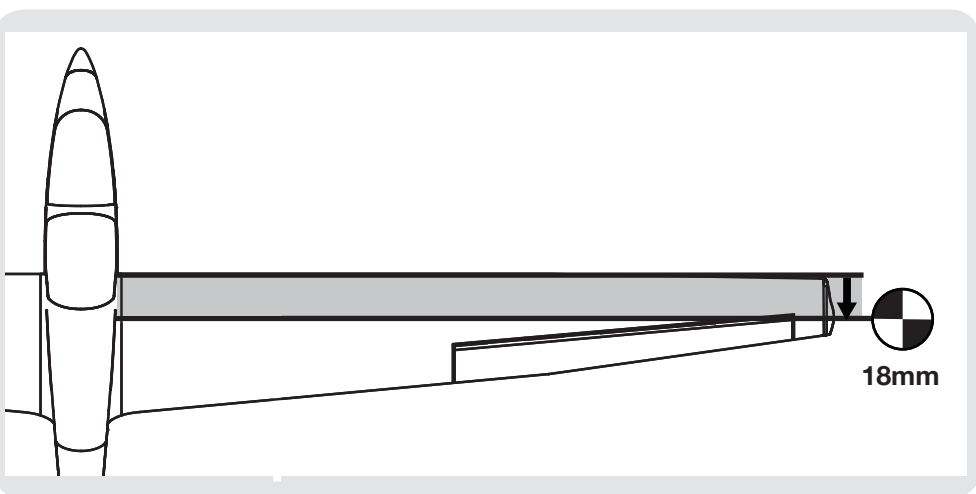

Hi-Start Hook Installation

1. Put the Hi-Start hook (A) in the slot in the bottom of the fuselage.
2. Install the screw (B) over the hook to hold it in place.

Disassemble in reverse order.

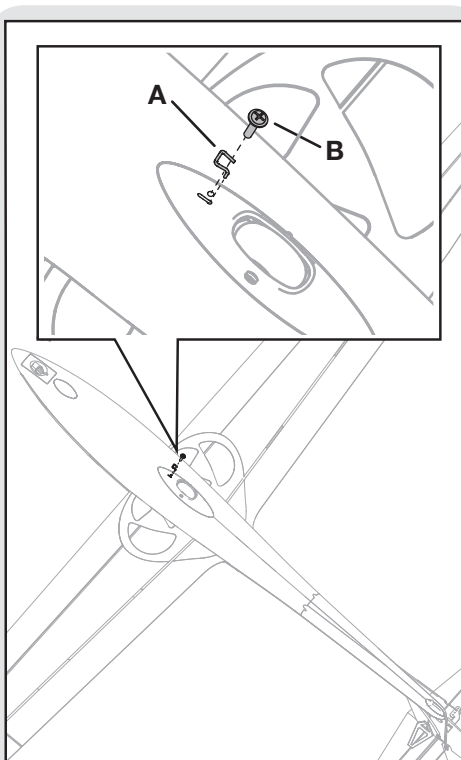
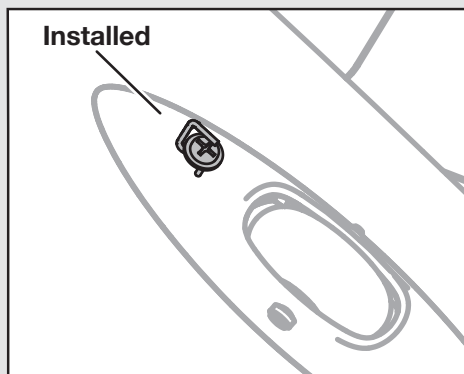

Hi-Start Launch

Included Hi-Start Equipment

The following is a list of included components that you will need to Hi-Start launch your ASK-21.

- Hi-Start and Stake [EFLU1258]
- Hi-Start Hook and Screw (EFLU1255)

Choosing a Launch Area

Your local AMA sanctioned flying field is the best location for flying. However, if you do not have access to such a field, many other open areas will work. Avoid possible damage to your launch system and aircraft by launching only in areas clear of brush, trees and other obstacles.

Preparation for Launch

You may need assistance to safely launch your aircraft using the included launch assembly. On your chosen flying field, anchor your launch assembly the furthest point upwind so that you can launch into the wind.

⚠ CAUTION: Avoid driving a stake into buried utility lines or damage and injury could result. Contact local utility authorities for assistance if needed.

Tip: For your first launches, aileron and elevator input should not be necessary and is not recommended. Use only the rudder to maintain a straight launch. Too much up elevator input can result in oscillations in the sailplane, which can overstrain the wings.

If you have any problems during launch, applying full down elevator will release the sailplane. Once it reaches its maximum launch altitude, the sailplane should release automatically. If it doesn't, a quick tap of down elevator will release it.

Hi-Start Launch (continued)

Do not attempt to fly or operate your ASK-21 any longer than 25 minutes on a battery.

1. Choose an anchor spot in firm soil and drive the stake at an approximate 45 degree angle to your chosen launch path (See image A).
2. Slide the rubber loop through the open section on the loop end of the stake. Pull on the assembly to ensure it is securely attached to the stake, and the stake is secure in the ground.
3. Unroll the assembly downwind from the stake, ensuring there are no tangles or knots. Once your assembly is completely laid out (but not stretched), slowly walk away from the stake, stretching the rubber.
4. Walk approximately **25 paces** and attach the string loop to the hi-start hook on the bottom of your airplane. Keep a firm grasp on your launch assembly and your aircraft. Ensure your transmitter and aircraft are powered on and bound together.
5. Toss the aircraft into the wind at a 30 degree upward angle (See Image B). During the launch, it may be necessary to use the transmitter to control the aircraft's swift movement. Keep in mind that the included launch assembly will unwind to approximately 120 feet (36 m) and will stretch an additional 75 to 100 feet (23 to 30 m).

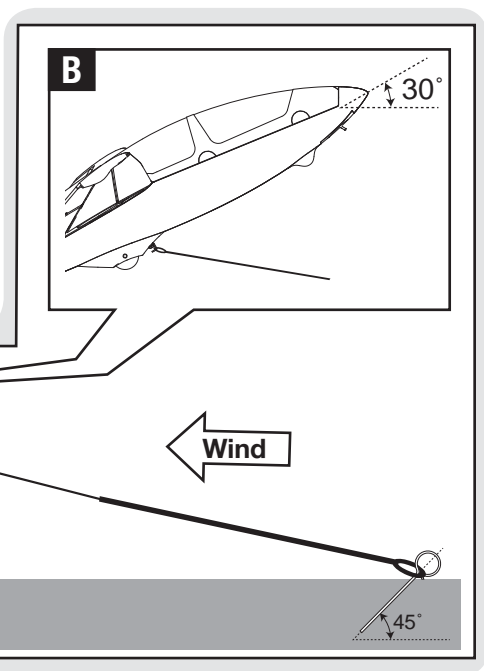
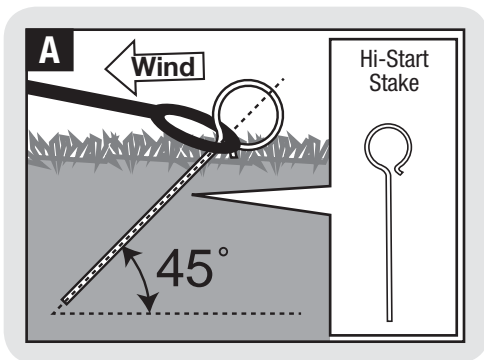

Stretch length for your launch assembly is based on normal wind conditions of about 5 mph (8 kph). Increase or decrease how far you stretch your launch assembly for the wind conditions. The windier it is, the less you should stretch the launch system. The calmer it is, the further you can stretch it. **Do not stretch further than 35 paces.**

Hi-Start Precautionary Guidelines

- Make sure the stake is securely anchored. Check throughout the day to make sure the stake is not loose. Reposition the stake if necessary to account for changing wind conditions.
- During the launch, make sure there is no one between you and the anchor stake.

- Do not over-stretch the rubber. Doing so can overstress the airplane, causing wing failure.
- Periodically check all knots. If the rubber or string shows wear, replace the assembly.

Maintenance and Storage

Extreme and/or prolonged heat decreases the life of rubber cord.

Store the assembly in a cool, dry place, loosely wound on a spool. Avoid leaving the assembly in an automobile. Preserve the rubber by applying a light dusting of talcum or baby powder. The powder decreases ground friction during use and adhesion during storage.

Towing

Towing with the Carbon Cub is only recommended for advanced pilots. While towing, be sure to fly in a large, open space. Also be sure that you have two pilots, one for the sailplane, and one for the towplane.

The E-flite® UMX ASK-21 sailplane is designed to be towed by the E-flite Carbon Cub (EFLU1180) from a smooth runway. A tow line (approximately 28 feet (8.5 m) long) is included with the UMX ASK-21 or is available separately (EFLU1257).

Do not attempt to fly or operate your ASK-21 any longer than 25 minutes on a battery.

1. Position both aircraft near each other on the runway, facing into the wind.
2. Tie the tow line to the tow plate on the Carbon Cub. Tie the other end of the tow line to the release mechanism under the nose of the E-flite UMX ASK-21 (see tow release installation section).
3. Space the aircraft apart so there is no slack in the tow line. If there is slack, it can result in damage to one or both of the aircraft.
4. **Ensure that the tow line is resting above the Carbon Cub's horizontal tail** so the Carbon Cub can pull the sailplane into the air safely.
5. Quickly apply power to the Carbon Cub once both pilots are ready for takeoff.
6. Keep the Carbon Cub on the ground until the sailplane and is 2–3 ft (0.9–1.2 m) above the Carbon Cub.
7. Slowly apply elevator to lift the Carbon Cub off of the ground. Be sure to keep the Carbon Cub under the sailplane until you have reached your release altitude.

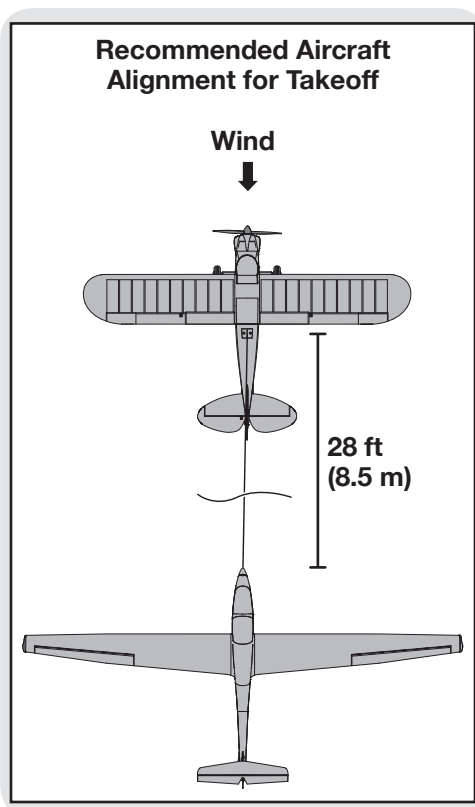

Recommended Aircraft Towing Positions When Flying

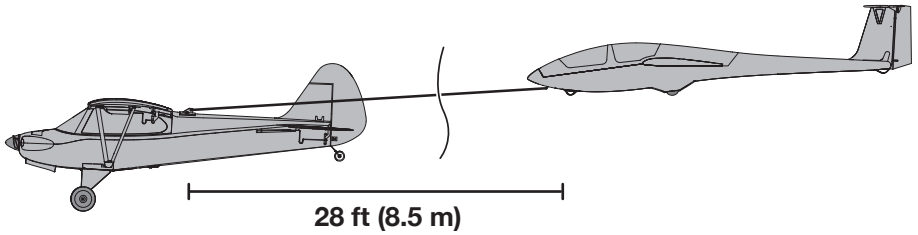

Tips for Towing

- Continually communicate with the pilot of the towplane and make sure they are aware when you are having difficulty, or are releasing the tow line.
- Ensure that you keep the sailplane's wings level at all times. You should not try to turn the aircraft, but rather allow the tow plane to drag the aircraft around turns.
- Avoid slack in the line while flying. Slack can cause the tow plane to abruptly pull the sailplane in unexpected directions. This can cause numerous problems and could result in a crash of one or both aircraft.
- Make only wide sweeping turns. Tight turns will result in the sailplane becoming unstable.

If a problem occurs, the pilot of the sailplane should release the tow line from the nose of his sailplane so that both aircraft can be safely landed.

NOTICE: Crash damage is not covered under warranty.

If there is a break in the tow line, tie the ends together securely or replace the line (EFLU1257) when needed.

Tow Release Installation

1. Activate the gear switch on your transmitter to retract the tow release pin.

NOTICE: Always ensure the pin (A) is retracted before putting the plate in the fuselage. Failure to do so may damage the aircraft and prevent tow release.

2. Align and install the tow plate (EFLU1255) (B) under the nose of the aircraft.
3. Move the Gear switch on your transmitter so the tow release pin holds the tow plate.

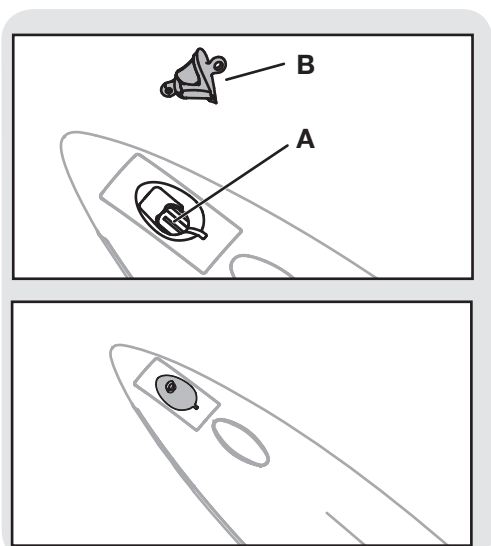

Flying Tips and Repairs

Flying

We recommend flying your E-flite® UMX ASK-21 outside in no greater than moderate winds. Always avoid flying near houses, trees, wires and buildings. You should also be careful to avoid flying in areas where there are many people, such as busy parks, schoolyards or soccer fields. Consult local laws and ordinances before choosing a location to fly your aircraft. For additional tips on flying your ASK-21, please refer to the product page at horizonhobby.com.

Your UMX ASK-21 can ascend on thermals and other updrafts to prolong its flight far beyond the flight time one would expect. There are many ways to stay aloft with a sailplane, such as ridge lifts and thermals, but we will only cover the basic thermal in this supplement. A thermal is simply a column of rising warm air. Once you get your aircraft into the air using the Hi-Start or aero-tow, watch your aircraft for a response to thermals. In a full-size sailplane, you would feel the lift of entering a thermal as turbulence. In the same way, watch your aircraft for movement or rising. If the airplane randomly rolls on its own, it is likely that you only flew through the edge of the thermal, causing one side of the airplane to rise, rather than the entire airplane. Enter the thermal by turning your aircraft directly into it, circling to stay in the center of the thermal. Slow your forward speed by increasing up elevator trim so that your aircraft is moving just faster than stall (minimum sink speed). Make easy banking turns to find the area of highest lift (the thermal's core). When you find the core of lift, tighten your turns to stay near this position. Sometimes thermals drift downwind. It is best that you search for thermals upwind, so that you can follow a thermal downwind if it is pushed downwind.

With practice, you will find it easier to locate and anticipate the movement of thermals.

Although thermals cannot be seen, you can see dust, insects or birds riding an updraft. Air movement of a thermal may be felt, so movement in an otherwise calm spot may show you the location of a nearby thermal. A shift in the wind (in a light breeze) can be airflow into a thermal. Thermals are generated by the sun heating darker ground objects more than surrounding surfaces. The dark object absorbs the sun's heat, becoming warm and heating the air above it. The heated air rises and forms a column or funnel. Usually the base of the thermal is small. The updraft expands and decreases in speed as the air rises and cools. There are usually downdrafts around the updraft, as cooler air falls or moves less than the warm updraft. Thermals can vary in strength, rising at speeds from a few hundred to over a thousand feet per minute. Cooler downdrafts around a thermal are referred to as "sink." Your aircraft can be pulled down by these downdrafts. Prevailing wind can also bend or break

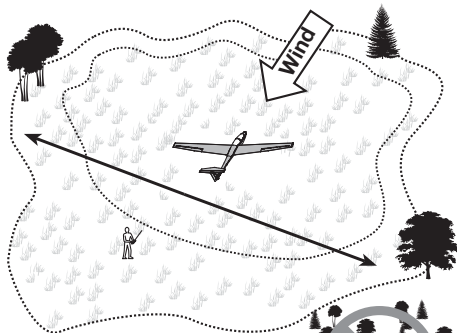

a thermal from its heat source so that a warm air bubble travels downwind as it rises with little or no attendant downdrafts.

Landing

Be sure to land into the wind. Due to the high lifting efficiency of the sailplane design, landing requires a large landing area clear of trees, buildings and cars. While on your downwind leg, remember that the sailplane glides much better than other aircraft. You will need to setup for landing, lower and with a more shallow decent than you may be used to. As you are on approach for landing ensure that the model is descending slowly, but also not accelerating. If the model is accelerating, it is likely that you will overshoot your projected landing area. Maintain this descent and speed, and, as the model nears the ground (approximately 6 inches (15 cm)), slowly apply a small amount of up elevator. The model should level out and fly parallel to the ground and begin to decelerate. Be sure the model does not climb. As it decelerates, keep flying the model parallel to the ground until it comes to rest gently on the landing gear.

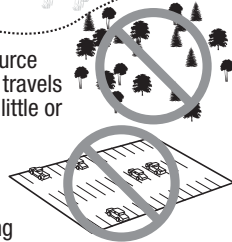

Low Voltage Cutoff (LVC)

Due to the aircraft having no motor and the small power needs of the sailplane, you may not know you have a low battery until controls fail. We recommend setting a timer for 25 minutes.

Do not attempt to fly or operate any longer than 25 minutes on a battery.

Repairs

NOTICE: Crash damage is not covered under warranty.

Repair this model using foam-compatible CA glue or clear tape. Only use foam-compatible CA glue as other types of glue can damage the foam. When parts are not repairable, see the Replacement Parts List for ordering by item number.

For a listing of all replacement and optional parts, refer to the list at the back of this manual.

NOTICE: Use of foam-compatible CA accelerant on your model can damage paint. DO NOT handle the model until accelerant fully dries.

Additional Safety Precautions and Warnings

As the user of this product, you are solely responsible for operating in a manner that does not endanger yourself and others or result in damage to the product or the property of others.

This model is controlled by a radio signal subject to interference from many sources outside your control. This interference can cause momentary loss of control, so it is advisable to always keep a safe distance in all directions around your model as this space will help avoid collisions or injury.

- Always keep a safe distance in all directions around your model to avoid collisions or injury.
- Always operate your model in open spaces away from full-size vehicles, traffic and people.
- Always carefully follow the directions and warnings for this and any optional support equipment (chargers, rechargeable battery packs, etc.).
- Always keep all chemicals, small parts and anything electrical out of the reach of children.
- Always avoid water exposure to all equipment not specifically designed and protected for this purpose. Moisture causes damage to electronics.
- Never place any portion of the model in your mouth as it could cause serious injury or even death.
- Never operate your model with low transmitter batteries.

Post Flight Checklist

✓	
	1. Disconnect flight battery from ESC (Required for Safety and battery life).
	2. Power off transmitter.
	3. Remove flight battery from aircraft.
	4. Recharge flight battery.

✓	
	5. Store flight battery apart from aircraft and monitor the battery charge.
	6. Make note of flight conditions and flight plan results, planning for future flights.

Troubleshooting Guide

AS3X

Problem	Possible Cause	Solution
Control surfaces not at neutral position when transmitter controls are at neutral	Control surfaces may not have been mechanically centered from factory	Center control surfaces mechanically by adjusting the U-bends on control linkages
	Aircraft was moved after the flight battery was connected and before sensors initialized	Disconnect and reconnect the flight battery while keeping the aircraft still for 5 seconds
Model flies inconsistently from flight to flight	Trims are moved too far from neutral position	Neutralize trims and mechanically adjust linkages to center control surfaces

Troubleshooting Guide (Continued)

Problem	Possible Cause	Solution
LED on receiver flashes and aircraft will not bind to transmitter (during binding)	Transmitter too near aircraft during binding process	Power off transmitter, move transmitter a larger distance from aircraft, disconnect and reconnect flight battery to aircraft and follow binding instructions
	Bind switch or button not held long enough during bind process	Power off transmitter and repeat bind process. Hold transmitter bind button or switch until receiver is bound
LED on receiver flashes rapidly and aircraft will not respond to transmitter (after binding)	Less than a 5-second wait between first powering on transmitter and connecting flight battery to aircraft	Leaving transmitter on, disconnect and reconnect flight battery to aircraft
	Aircraft bound to different model memory (ModelMatch™ radios only)	Select correct model memory on transmitter and disconnect and reconnect flight battery to aircraft
	Flight battery/transmitter battery charge is too low	Replace/recharge batteries
Control surface does not move	Control surface, control horn, linkage or servo damage	Replace or repair damaged parts and adjust controls
	Wire damaged or connections loose	Do a check of wires and connections, connect or replace as needed
	Flight battery charge is low	Fully recharge flight battery
	Control linkage does not move freely	Make sure control linkage moves freely
Controls reversed	Transmitter settings reversed	Adjust controls on transmitter appropriately
Servo locks or freezes at full travel	Travel adjust value is set above 100% overdriving the servo	Set Travel adjust to 100% or less and/or set sub-trims to Zero and adjust linkages mechanically

Limited Warranty

What this Warranty Covers

Horizon Hobby, Inc. ("Horizon") warrants to the original purchaser that the product purchased (the "Product") will be free from defects in materials and workmanship at the date of purchase.

What is Not Covered

This warranty is not transferable and does not cover (i) cosmetic damage, (ii) damage due to acts of God, accident, misuse, abuse, negligence, commercial use, or due to improper use, installation, operation or maintenance, (iii) modification of or to any part of the Product, (iv) attempted service by anyone other than a Horizon Hobby authorized service center, (v) Product not purchased from an authorized Horizon dealer, or (vi) Product not compliant with applicable technical regulations.

OTHER THAN THE EXPRESS WARRANTY ABOVE, HORIZON MAKES NO OTHER WARRANTY OR REPRESENTATION, AND HEREBY DISCLAIMS ANY AND ALL IMPLIED WARRANTIES, INCLUDING, WITHOUT LIMITATION, THE IMPLIED WARRANTIES OF NON-INFRINGEMENT, MERCHANTABILITY AND FITNESS FOR A PARTICULAR PURPOSE. THE PURCHASER ACKNOWLEDGES THAT THEY ALONE HAVE

DETERMINED THAT THE PRODUCT WILL SUITABLY MEET THE REQUIREMENTS OF THE PURCHASER'S INTENDED USE.

Purchaser's Remedy

Horizon's sole obligation and purchaser's sole and exclusive remedy shall be that Horizon will, at its option, either (i) service, or (ii) replace, any Product determined by Horizon to be defective. Horizon reserves the right to inspect any and all Product(s) involved in a warranty claim. Service or replacement decisions are at the sole discretion of Horizon. Proof of purchase is required for all warranty claims. SERVICE OR REPLACEMENT AS PROVIDED UNDER THIS WARRANTY IS THE PURCHASER'S SOLE AND EXCLUSIVE REMEDY.

Limitation of Liability

HORIZON SHALL NOT BE LIABLE FOR SPECIAL, INDIRECT, INCIDENTAL OR CONSEQUENTIAL DAMAGES, LOSS OF PROFITS OR PRODUCTION OR COMMERCIAL LOSS IN ANY WAY, REGARDLESS OF WHETHER SUCH CLAIM IS BASED IN CONTRACT, WARRANTY, TORT, NEGLIGENCE, STRICT LIABILITY OR ANY OTHER THEORY OF LIABILITY, EVEN IF HORIZON HAS BEEN ADVISED OF THE POSSIBILITY

OF SUCH DAMAGES. Further, in no event shall the liability of Horizon exceed the individual price of the Product on which liability is asserted. As Horizon has no control over use, setup, final assembly, modification or misuse, no liability shall be assumed nor accepted for any resulting damage or injury. By the act of use, setup or assembly, the user accepts all resulting liability. If you as the purchaser or user are not prepared to accept the liability associated with the use of the Product, purchaser is advised to return the Product immediately in new and unused condition to the place of purchase.

Law

These terms are governed by Illinois law (without regard to conflict of law principals). This warranty gives you specific legal rights, and you may also have other rights which vary from state to state. Horizon reserves the right to change or modify this warranty at any time without notice.

WARRANTY SERVICES

Questions, Assistance, and Services

Your local hobby store and/or place of purchase cannot provide warranty support or service. Once assembly, setup or use of the Product has been started, you must contact your local distributor or Horizon directly. This will enable Horizon to better answer your questions and service you in the event that you may need any assistance. For questions or assistance, please visit our website at www.horizonhobby.com, submit a Product Support Inquiry, or call 877.504.0233 toll free to speak to a Product Support representative.

Inspection or Services

If this Product needs to be inspected or serviced and is compliant in the country you live and use the Product in, please use the Horizon Online Service Request submission process found on our website or call Horizon to obtain a Return Merchandise Authorization (RMA) number. Pack the Product securely using a shipping carton. Please note that original boxes may be included, but are not designed to withstand the rigors of shipping without additional protection. Ship via a carrier that provides tracking and insurance for lost or damaged parcels, as Horizon is not responsible for merchandise until it arrives and is accepted at our facility. An Online Service Request is available at http://www.horizonhobby.com/content/_service-center_render-service-center. If you do not have internet access, please contact Horizon Product Support to obtain a RMA number along with instructions for submitting your product for service. When calling Horizon, you will be asked to provide your complete name, street address, email address and phone number where you can be reached during business hours. When sending product into Horizon, please include your RMA number, a list of the included items, and a brief summary of the problem. A copy of your original sales receipt must be included for warranty consideration. Be sure your name, address, and RMA number are clearly written on the outside of

the shipping carton.

NOTICE: Do not ship LiPo batteries to Horizon. If you have any issue with a LiPo battery, please contact the appropriate Horizon Product Support office.

Warranty Requirements

For Warranty consideration, you must include your original sales receipt verifying the proof-of-purchase date. Provided warranty conditions have been met, your Product will be serviced or replaced free of charge. Service or replacement decisions are at the sole discretion of Horizon.

Non-Warranty Service

Should your service not be covered by warranty, service will be completed and payment will be required without notification or estimate of the expense unless the expense exceeds 50% of the retail purchase cost. By submitting the item for service you are agreeing to payment of the service without notification. Service estimates are available upon request. You must include this request with your item submitted for service. Non-warranty service estimates will be billed a minimum of ½ hour of labor. In addition you will be billed for return freight. Horizon accepts money orders and cashier's checks, as well as Visa, MasterCard, American Express, and Discover cards. By submitting any item to Horizon for service, you are agreeing to Horizon's Terms and Conditions found on our website http://www.horizonhobby.com/content/_service-center_render-service-center.

NOTICE: Horizon service is limited to Product compliant in the country of use and ownership. If non-compliant product is received by Horizon for service, it will be returned unserviced at the sole expense of the purchaser.

Warranty and Service Information

Country of Purchase	Horizon Hobby	Address	Phone Number/Email Address
United States of America	Horizon Service Center (Electronics and engines)	4105 Fieldstone Rd Champaign, Illinois 61822 USA	877-504-0233 Online Repair Request visit: www.horizonhobby.com/service
	Horizon Product Support (All other products)	4105 Fieldstone Rd Champaign, Illinois 61822 USA	877-504-0233 productsupport@horizonhobby.com
United Kingdom	Horizon Hobby Limited	Units 1-4 Ployters Rd Staple Tye Harlow, Essex CM18 7NS United Kingdom	+44 (0) 1279 641 097 sales@horizonhobby.co.uk
Germany	Horizon Technischer Service	Christian-Junge-Straße 1 25337 Elmshorn Germany	+49 (0) 4121 2655 100 service@horizonhobby.de
France	Horizon Hobby SAS	14 Rue Gustave Eiffel Zone d'Activité du Réveil Matin 91230 Montgeron	+33 (0) 1 60 47 44 70 infofrance@horizonhobby.com
China	Horizon Hobby – China	Room 506, No. 97 Changshou Rd. Shanghai, China, 200060	+86 (021) 5180 9868 info@horizonhobby.com.cn

Compliance Information for the European Union

Declaration of Conformity

(in accordance with ISO/IEC 17050-1)
No. HH2012032301

	Product(s):	EFL UMX ASK-21 BNF
	Item Number(s):	EFLU1280
	Equipment class:	1

The object of declaration described above is in conformity with the requirements of the specifications listed below, following the provisions of the European R&TTE directive 1999/5/EC and EMC Directive 2004/108/EC:

EN 301 489-1 V1.7.1: 2006
EN 301 489-17 V1.3.2: 2008

EN55022: 2010
EN55024: 2010

Signed for and on behalf of:
Horizon Hobby, Inc.
Champaign, IL USA
March 23, 2012

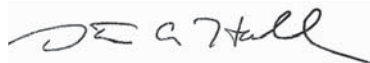

Steven A. Hall
Vice President
International Operations and Risk Management
Horizon Hobby, Inc.

Instructions for disposal of WEEE by users in the European Union



This product must not be disposed of with other waste. Instead, it is the user's responsibility to dispose of their waste equipment by handing it over to a designated collections point for the recycling of waste electrical and electronic equipment. The separate collection and recycling of your waste equipment at the time of disposal will help to conserve natural resources and ensure that it is recycled in a manner that protects human health and the environment. For more information about where you can drop off your waste equipment for recycling, please contact your local city office, your household waste disposal service or where you purchased the product.

– Replacement Parts –
– Ersatzteile –
– Pièces de rechange –
– Recapiti per i ricambi –

Part # • Nummer Numéro • Codice	Description	Beschreibung	Description	Descrizione
EFLU1257	Replacement Tow Line: UMX ASK-21	Ersatzschlepplaine : Ultra Micro ASK-21	Câble de remorquage de remplacement: UMX ASK-21	Rimpiazzo cavo traino: UMX ASK-21
EFLU1258	Replacement HI-Start and stake: UMX ASK-21	Hochstartgummi und Bodenanker : Ultra Micro ASK-21	Elastique et Piquet-Crochet HI-Start : UMX ASK-21	Cavo elastico con picchetto : UMX ASK-21
EFLU1220	Main Wing Set: UMX ASK-21	Tragflächenset : Ultra Micro ASK-21	Jeu aile principale : UMX ASK-21	Set ala principale: UMX ASK-21
EFLU1202	Decal Set: UMX ASK-21	Dekorbogen Set : Ultra Micro ASK-21	Jeu de décalcomanies : UMX ASK-21	Set decalcomanie UMX ASK-21
EFLU1204	Clear Canopy Hatch: UMX ASK-21	Kabinenhaube klar : Ultra Micro ASK-21	Canopy transparent : UMX ASK-21	Portello tettuccio trasparente: UMX ASK-21
EFLU1225	Complete Tail Set: UMX ASK-21	Leitwerk kpl. Set: Ultra Micro ASK-21	Set d'empennage : UMX ASK-21	Set piani di coda: UMX ASK-21
EFLU1226	Pushrod Set: UMX ASK-21	Gestänge Set: Ultra Micro ASK-21	Jeu de tiges : UMX ASK-21	Set aste rinvi: UMX ASK-21
EFLU1255	Launch and Release Replacement parts: UMX ASK-21	Start und Schlepper-satzteile : Ultra Micro ASK-21	Eléments de remplacement pour les systèmes de Lancement et de Lâcher: UMX ASK-21	Sostituzioni meccanismi di sgancio e lancio: UMX ASK-21
EFLU1256	Hardware Set: UMX ASK-21	Kleinteile Set: Ultra Micro ASK-21	Set de quincaillerie : UMX ASK-21	Set accessori di fissaggio: UMX ASK-21
EFLU1267	Bare Fuse w/Hatch: UMX ASK-21	Rumpf mit Haube : Ultra Mikro ASK-21	Fuselage nu avec canopy : UMX ASK-21	Fusoliera con portello: UMX ASK-21
EFLB1501S25	150mAh 1S 3.7V 25C Li-Po	150mAh 1S 3,7V 25C Li-Po Akku	Batterie Li-Po 3.7V 1S 150mA 25C	Batteria Li-Po150mAh 1S 3.7V 25C
EFLC1000	AC/DC 3.7V Li-Po Charger	AC/DC-3,7V-Li-Po-Ladegerät	Chargeur Li-Po CA/DC 3,7V	Caricabatterie Li-Po CA/CC da 3,7V
SPMSA2030LO	2.3 g Liner Long Offset Servo (ailerons)	2,3 Gramm Linear Offset Servo (Querruder)	Servo linéaire offset course longue 2,3 g (Ailerons)	Servo lineare corsa lunga alte prestazioni 2,3 grammi (Alettoni)
SPMSA2030L	2.3-Gram Performance Linear Long Throw Servo (release)	Spektrum 2;3-Gramm Performance Linear Servo m. langem Ruderweg	Servo Performance Linear Long Throw 2,3 g (relâchement)	2.3 grammi servo a corsa lunga per alte prestazioni (rilascio)
SPM6836	Servo Mechanics: 2.3 G 2030L	Spektrum Ersatzgetriebe Servo: 2.3-Gram 2030L	Mécaniques servo : 2.3 G 2030L	Meccanica del servo: 2.3 G 2030L
EFLU1264	DSM2/X 6Ch UM AS3X Receiver ESC - ASK-21	E-flite DSM2/DSMX 6 Kanal UM AS3X Empfänger/Regler: ASK-21	DSM2/X 6Ch UM CEV Récepteur AS3X-ASK-21	DSM2/X 6Ch UM AS3X Ricevitore ESC - ASK-21

– Optional Parts and Accessories –
– Optionale Bauteile und Zubehörteile –
– Pièces optionnelles et accessoires –
– Parti opzionali e accessori –

Part # • Nummer Numéro • Codice	Description	Beschreibung	Description	Descrizione
EFLC1004	Celectra 4-Port 1S 3.7V 0.3 A DC Li-Po Charger	Celectra-1S-3,7V- 0,3ADC- Li-Po- Ladegerät mit 4 Anschlüssen	Chargeur Li-Po CC 0,3 A 3, 7V 1S 4 ports Celectra	Caricabatteria Li-Po 1S da 3,7V 0,3 A CC, a 4 porte, Celectra
EFLC1005/AU/ EU/UK	AC to 6V DC 1.5 amp Power Supply (Based upon your sales Region)	Netzteil 6V 1,5 A (Basierend nach Vertriebsregion)	Alimentation CA vers 6V CC, 1,5 A (En fonction de votre région)	Alimentatore CA - 6V CC da 1,5 A (in base al Paese di vendita)
	DX5e DSMX 5-channel Transmitter	Spektrum DX5e DSMX 5 Kanalsender ohne Empfänger	Emetteur DX5e DSMX 5 voies	DX5e DSMX Trasmettitore 5 canali
	DX6i DSMX 6-Channel Transmitter	DX6i DSMX 6-Kanal Sender	Emetteur DX6i DSMX 6 voies	DX6i DSMX Trasm- titore 6 canali
	DX7s DSMX 7-Channel Transmitter	Spektrum DX7s 7 Kanal Sender	Emetteur DX7s DSMX 7 voies	DX7s DSMX Trasmettitore 7 canali
	DX8 DSMX Transmitter	Spektrum DX8 nur Sender	Emetteur DX8 DSMX 8 voies	DX8 DSMX Solo trasmettitore

– Parts Contact Information –
– Intaktinformationen für Ersatzteile –
– Coordonnés pour obtenir de pièces détachées –
– Recapiti per i ricambi –

Country of Purchase	Horizon Hobby	Address	Phone Number/Email Address
United States	Sales	4105 Fieldstone Rd Champaign, Illinois, 61822 USA	800-338-4639 sales@horizonhobby.com
United Kingdom	Horizon Hobby Limited	Units 1-4 Ployters Rd Staple Tye Harlow, Essex CM18 7NS, United Kingdom	+44 (0) 1279 641 097 sales@horizonhobby.co.uk
Germany	Horizon Hobby GmbH	Christian-Junge-Straße 1 25337 Elmshorn, Germany	+49 (0) 4121 2655 100 service@horizonhobby.de
France	Horizon Hobby SAS	14 Rue Gustave Eiffel Zone d'Activité du Réveil Matin 91230 Montgeron	+33 (0) 1 60 47 44 70 infofrance@horizonhobby.com
China	Horizon Hobby – China	Room 506, No. 97 Changshou Rd. Shanghai, China, 200060	+86 (021) 5180 9868 info@horizonhobby.com.cn

© 2012 Horizon Hobby, Inc.

UMX, AS3X, E-flite, JR, Celectra, DSM2, ModelMatch and Bind-N-Fly are trademarks or registered trademarks of Horizon Hobby, Inc.

DSMX is a trademark of Horizon Hobby, Inc., registered in the U.S.

The Spektrum trademark is used with permission of Bachmann Industries, Inc.

Futaba is a registered trademark of Futaba Denshi Kogyo Kabushiki Kaisha Corporation of Japan.

Cub Crafters, Carbon Cub, associated emblems and logos, and body designs of vehicles are either registered trademarks or trademarks of Cub Crafters, Inc. and are used with permission.

US D578,146. PRC ZL 200720069025.2. US 7,898,130. Other patents pending.

www.e-fliterc.com

